

## Grad, Div, Curl, and Laplacian

**CARTESIAN**     $d\ell = x\hat{x} + y\hat{y} + z\hat{z}$      $d^3r = dx dy dz$

$$\nabla\psi = \frac{\partial\psi}{\partial x}\hat{x} + \frac{\partial\psi}{\partial y}\hat{y} + \frac{\partial\psi}{\partial z}\hat{z}$$

$$\nabla \cdot \mathbf{A} = \frac{\partial A_x}{\partial x} + \frac{\partial A_y}{\partial y} + \frac{\partial A_z}{\partial z}$$

$$\nabla \times \mathbf{A} = \left(\frac{\partial A_z}{\partial y} - \frac{\partial A_y}{\partial z}\right)\hat{x} + \left(\frac{\partial A_x}{\partial z} - \frac{\partial A_z}{\partial x}\right)\hat{y} + \left(\frac{\partial A_y}{\partial x} - \frac{\partial A_x}{\partial y}\right)\hat{z}$$

$$\nabla^2\psi = \frac{\partial^2\psi}{\partial x^2} + \frac{\partial^2\psi}{\partial y^2} + \frac{\partial^2\psi}{\partial z^2}$$

---

**CYLINDRICAL**     $d\ell = d\rho\hat{\rho} + \rho d\phi\hat{\phi} + dz\hat{z}$      $d^3r = \rho d\rho d\phi dz$

$$\nabla\psi = \frac{\partial\psi}{\partial\rho}\hat{\rho} + \frac{1}{\rho}\frac{\partial\psi}{\partial\phi}\hat{\phi} + \frac{\partial\psi}{\partial z}\hat{z}$$

$$\nabla \cdot \mathbf{A} = \frac{1}{\rho}\frac{\partial}{\partial\rho}(\rho A_\rho) + \frac{1}{\rho}\frac{\partial A_\phi}{\partial\phi} + \frac{\partial A_z}{\partial z}$$

$$\nabla \times \mathbf{A} = \left(\frac{1}{\rho}\frac{\partial A_z}{\partial\phi} - \frac{\partial A_\phi}{\partial z}\right)\hat{\rho} + \left(\frac{\partial A_\rho}{\partial z} - \frac{\partial A_z}{\partial\rho}\right)\hat{\phi} + \frac{1}{\rho}\left[\frac{\partial}{\partial\rho}(\rho A_\phi) - \frac{\partial A_\rho}{\partial\phi}\right]\hat{z}$$

$$\nabla^2\psi = \frac{1}{\rho}\frac{\partial}{\partial\rho}\left(\rho\frac{\partial\psi}{\partial\rho}\right) + \frac{1}{\rho^2}\frac{\partial^2\psi}{\partial\phi^2} + \frac{\partial^2\psi}{\partial z^2}$$

---

**SPHERICAL**     $d\ell = dr\hat{r} + r d\theta\hat{\theta} + r \sin\theta d\phi\hat{\phi}$      $d^3r = r^2 \sin\theta dr d\theta d\phi$

$$\nabla\psi = \frac{\partial\psi}{\partial r}\hat{r} + \frac{1}{r}\frac{\partial\psi}{\partial\theta}\hat{\theta} + \frac{1}{r\sin\theta}\frac{\partial\psi}{\partial\phi}\hat{\phi}$$

$$\nabla \cdot \mathbf{A} = \frac{1}{r^2}\frac{\partial}{\partial r}(r^2 A_r) + \frac{1}{r\sin\theta}\frac{\partial}{\partial\theta}(\sin\theta A_\theta) + \frac{1}{r\sin\theta}\frac{\partial A_\phi}{\partial\phi}$$

$$\nabla \times \mathbf{A} = \frac{1}{r\sin\theta}\left[\frac{\partial}{\partial\theta}(\sin\theta A_\phi) - \frac{\partial A_\phi}{\partial\theta}\right]\hat{r} + \left[\frac{1}{r\sin\theta}\frac{\partial A_r}{\partial\phi} - \frac{1}{r}\frac{\partial}{\partial r}(r A_\phi)\right]\hat{\theta} + \frac{1}{r}\left[\frac{\partial}{\partial r}(r A_\theta) - \frac{\partial A_r}{\partial\theta}\right]\hat{\phi}$$

$$\nabla^2\psi = \frac{1}{r^2}\frac{\partial}{\partial r}\left(r^2\frac{\partial\psi}{\partial r}\right) + \frac{1}{r^2\sin\theta}\frac{\partial}{\partial\theta}\left(\sin\theta\frac{\partial\psi}{\partial\theta}\right) + \frac{1}{r^2\sin^2\theta}\frac{\partial^2\psi}{\partial\phi^2}$$

Figure 1: Grad, Div, Curl, Laplacian in cartesian, cylindrical, and spherical coordinates. Here  $\psi$  is a scalar function and  $\mathbf{A}$  is a vector field.

### Vector Identities

$$\mathbf{a} \cdot (\mathbf{b} \times \mathbf{c}) = \mathbf{b} \cdot (\mathbf{c} \times \mathbf{a}) = \mathbf{c} \cdot (\mathbf{a} \times \mathbf{b})$$

$$\mathbf{a} \times (\mathbf{b} \times \mathbf{c}) = (\mathbf{a} \cdot \mathbf{c})\mathbf{b} - (\mathbf{a} \cdot \mathbf{b})\mathbf{c}$$

$$(\mathbf{a} \times \mathbf{b}) \cdot (\mathbf{c} \times \mathbf{d}) = (\mathbf{a} \cdot \mathbf{c})(\mathbf{b} \cdot \mathbf{d}) - (\mathbf{a} \cdot \mathbf{d})(\mathbf{b} \cdot \mathbf{c})$$

$$\nabla \times \nabla \psi = 0$$

$$\nabla \cdot (\nabla \times \mathbf{a}) = 0$$

$$\nabla \times (\nabla \times \mathbf{a}) = \nabla(\nabla \cdot \mathbf{a}) - \nabla^2 \mathbf{a}$$

$$\nabla \cdot (\psi \mathbf{a}) = \mathbf{a} \cdot \nabla \psi + \psi \nabla \cdot \mathbf{a}$$

$$\nabla \times (\psi \mathbf{a}) = \nabla \psi \times \mathbf{a} + \psi \nabla \times \mathbf{a}$$

$$\nabla(\mathbf{a} \cdot \mathbf{b}) = (\mathbf{a} \cdot \nabla)\mathbf{b} + (\mathbf{b} \cdot \nabla)\mathbf{a} + \mathbf{a} \times (\nabla \times \mathbf{b}) + \mathbf{b} \times (\nabla \times \mathbf{a})$$

$$\nabla \cdot (\mathbf{a} \times \mathbf{b}) = \mathbf{b} \cdot (\nabla \times \mathbf{a}) - \mathbf{a} \cdot (\nabla \times \mathbf{b})$$

$$\nabla \times (\mathbf{a} \times \mathbf{b}) = \mathbf{a}(\nabla \cdot \mathbf{b}) - \mathbf{b}(\nabla \cdot \mathbf{a}) + (\mathbf{b} \cdot \nabla)\mathbf{a} - (\mathbf{a} \cdot \nabla)\mathbf{b}$$

### Integral Identities

$$\int_V d^3r \nabla \cdot \mathbf{A} = \int_S dS \hat{\mathbf{n}} \cdot \mathbf{A}$$

$$\int_V d^3r \nabla \psi = \int_S dS \hat{\mathbf{n}} \psi$$

$$\int_V d^3r \nabla \times \mathbf{A} = \int_S dS \hat{\mathbf{n}} \times \mathbf{A}$$

$$\int_S dS \hat{\mathbf{n}} \cdot \nabla \times \mathbf{A} = \oint_C d\ell \cdot \mathbf{A}$$

$$\int_S dS \hat{\mathbf{n}} \times \nabla \psi = \oint_C d\ell \psi$$

Figure 2: Vector and integral identities. Here  $\psi$  is a scalar function and  $\mathbf{A}$ ,  $\mathbf{a}$ ,  $\mathbf{b}$ ,  $\mathbf{c}$  are vector fields.

$P_0(x)$	1
$P_1(x)$	$x$
$P_2(x)$	$\frac{1}{2}(3x^2 - 1)$
$P_3(x)$	$\frac{1}{2}(5x^3 - 3x)$
$P_4(x)$	$\frac{1}{8}(35x^4 - 30x^2 + 3)$

Table 1: The Lowest Legendre Polynomials

**Problem 1. A dielectric sphere in an external field with a gradient**

A dielectric sphere of radius  $a$  at the origin is placed in an external field with a constant small gradient  $\partial_z E_z \equiv E'_o$ , so that the external potential is described by

$$\varphi_{\text{ext}}(\mathbf{r}) = -E_o z - \frac{1}{2} E'_o (z^2 - \frac{1}{2}(x^2 + y^2)) \quad (1)$$

The gradient is very small since  $E'_o a \ll E_o$

- (a) Determine the potential both inside and outside the sphere including the first correction due to the field gradient. Start by expressing the external potential in  $r$  and  $\theta$ .
- (b) Determine the surface charge induced on the sphere including the first correction due to the field gradient.

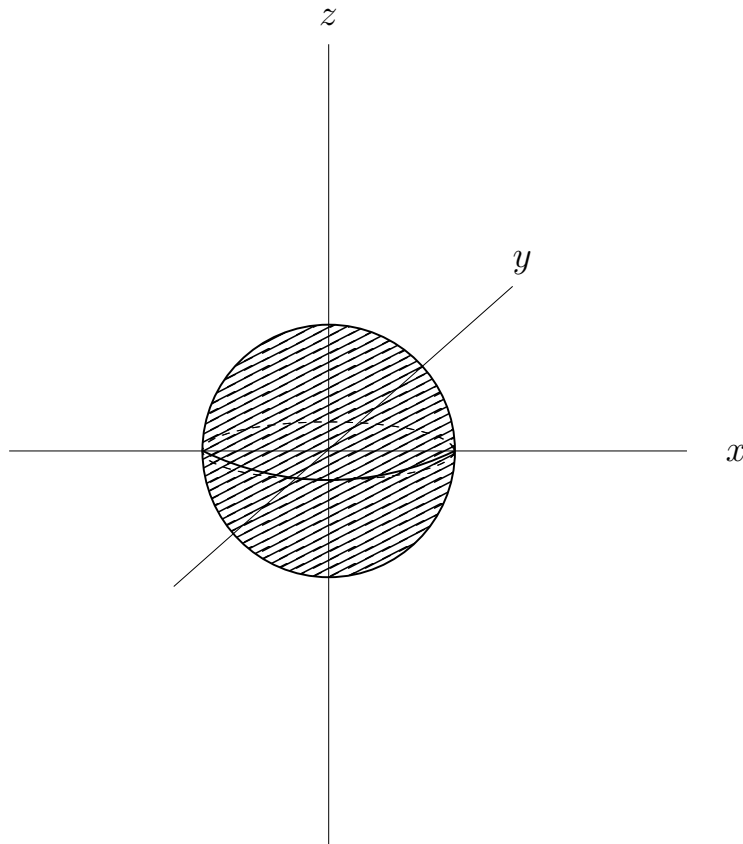

## Problem 2. Forces on a filled solenoid

An infinitely long solenoid of radius  $a$  with  $n$  turns per length carrying a current  $I(t) = I_0 e^{i\omega t}$  is filled with a linear (non-conducting) magnetic material with permeability  $\mu$  and dielectric constant  $\epsilon = 1$ . The axis of the solenoid is aligned with the  $z$  axis. The fields vary sinusoidally,  $\mathbf{B}(\mathbf{x}, t) = \mathbf{B}(\mathbf{x})e^{-i\omega t}$  and  $\mathbf{E}(\mathbf{x}, t) = \mathbf{E}(\mathbf{x})e^{-i\omega t}$ .

- (a) Determine the magnetic field and inductance  $\mathbf{B}(\mathbf{x})$  and  $\mathbf{H}(\mathbf{x})$  inside and outside the solenoid to zeroth order in the quasi-static approximation, *i.e.* at zeroth order the current  $I(t)$  is effectively constant in time.
- (b) Determine the surface currents on the magnetic material to zeroth order in the quasi-static approximation.
- (c) Compute the time-averaged force per area on the sides of the solenoid in the zeroth order approximation.
- (d) Determine the the electric field inside and outside of the solenoid in a quasi-static approximation. Explain why  $\mathbf{E}(\mathbf{x})$  is continuous across the solenoid interface.
- (e) What is the condition that the quasi-static approximation is valid, and verify that your solution in part (d) satisfies this criterion.
- (f) Determine quasi-static correction to the magnetic field,  $\delta\mathbf{H}(\mathbf{x})$  just outside the solenoid at  $\rho = a + \text{tiny}$ . Assume that at a large radius,  $\rho_{\max}$ , that  $\delta\mathbf{H}(\mathbf{x}) \simeq 0$ . Explain why the correction  $\delta\mathbf{H}(\mathbf{x})$  is continuous across the solenoid interface.
- (g) Find the quasi-static correction to the time-averaged force per area on solenoid computed in (c).

### Problem 3. Transmission through a glass plane

- (a) For a plane wave in linear media, show using the Maxwell equations (and nothing else), that if

$$\mathbf{E}(\mathbf{r}, t) = \vec{\mathcal{E}} e^{i\mathbf{k}\cdot\mathbf{r} - i\omega t}, \quad (2)$$

then  $\omega = ck/n$  with  $n = \sqrt{\mu\epsilon}$  and

$$\mathbf{H}(\mathbf{r}, t) = \vec{\mathcal{H}} e^{i\mathbf{k}\cdot\mathbf{r} - i\omega t} \quad (3)$$

with

$$\vec{\mathcal{H}} = \frac{1}{Z} \hat{\mathbf{k}} \times \vec{\mathcal{E}} \quad (4)$$

and  $Z = \sqrt{\mu/\epsilon}$

- (b) Consider a plane wave in a linear medium with  $\mu_1, \epsilon_1$  of wave-number  $k$ , normally incident on a semi-infinite block of linear media with  $\mu_2, \epsilon_2$ . Starting from the Maxwell equations with boundary conditions, explicitly determine the transmission amplitude  $t$  (the ratio of transmitted electric field to incident electric field) and the power transmission coefficient  $T_p$ .

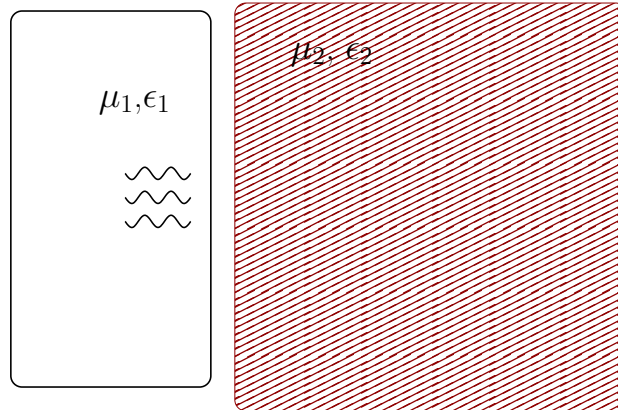

- (c) Now consider a plane wave in vacuum of wave-number  $k$ , normally incident on a slab of linear material dielectric constant  $\epsilon$  and magnetic permeability  $\mu$  and width  $d$ . Set up a set of linear equations which can be used to solve for transmission amplitude using mathematica, but do not try to solve.

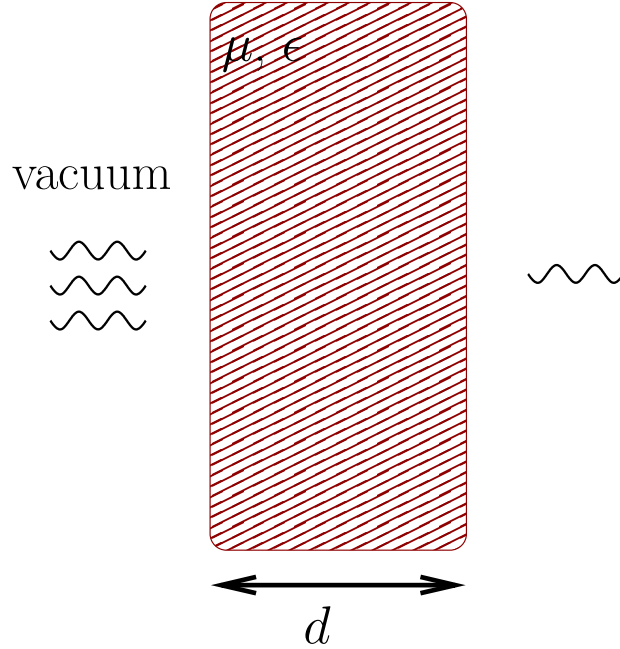

(d) The transmission coefficient for the slab just described is

$$T_p = \left| \frac{4Z}{(1+Z)^2 - (Z-1)^2 e^{2indk}} \right|^2 \quad (5)$$

which for  $Z$  large clearly shows several distinct maxima, whenever  $nk d = m\pi$ . Here  $n = \sqrt{\mu\epsilon}$  is the index of refraction and  $m$  is an integer.

Consider a relatively narrow Gaussian wave packet of mean wave-number  $\bar{k}$  and spatial extent  $\Delta x$ , with  $(\Delta x)\bar{k} \gg 1$ . Qualitatively sketch (*i.e.* without calculation) what the transmission coefficient would look like as a function of  $n\bar{k}d$  and relatively large  $Z$ . For definiteness take  $(\Delta x)\bar{k} \simeq 12$  and  $Z = 5$ . Describe the  $d \rightarrow \infty$  limit using the results of part (b).